

# VIZU® GLASS MERCHANDISER

VIGM-T



- Perfect for holding prepared nachos and dipping sauce
- Reconfigurable shelves to suit packaging and product sizes
- Suited for top counter to display the product to customers.
- Stainless steel construction with glass for full view of the product.

**VIZU® Glass Merchandiser Specification Page**

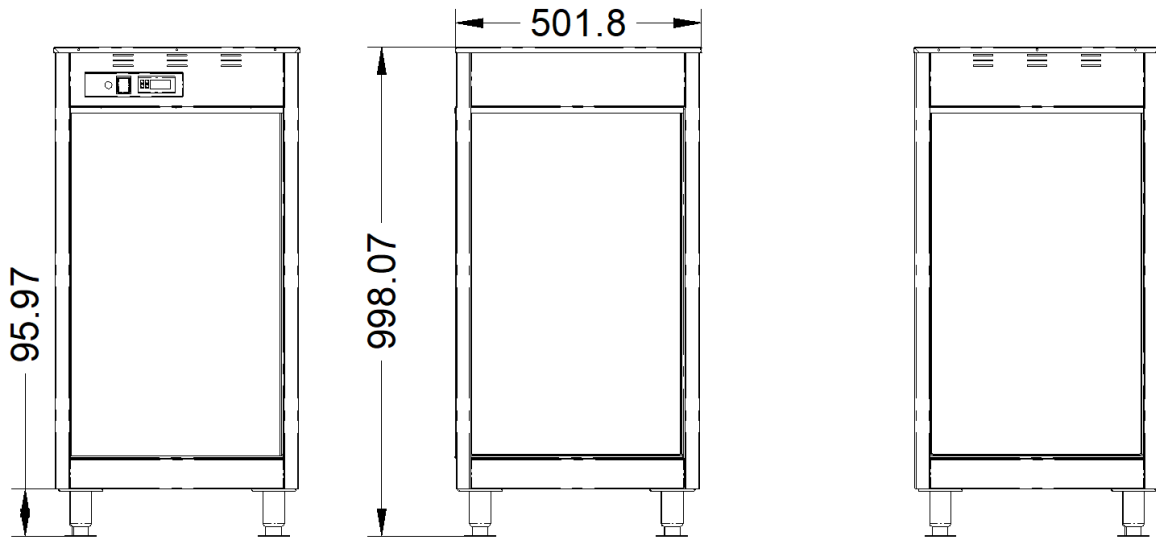

**Model: VIGM-T**

<b>Dimensions</b>	<b>Machine</b>
Height	998mm
Width	501mm
Depth	496mm
<b>Weight</b>	45kg
<b>Electrical</b>	1 phase, 50HZ AC, 0.9Kw, 230v
Running Amps	2.6 Amps
Connection Type	BSCHUKO 2/3 PIN PLUG
International Option	N/A

All **Vizu® Glass Merchandiser** have been tested and checked for proper operation before leaving the Fast Food Systems manufacturing facility.

Upon delivery please check the unit for damage. If the unit is damaged, contact the carrier, or Fast Food Systems, immediately and file a damage claim (found in the back of the manual) Please retain all packing materials.

## **Damage must be reported within 7 days of delivery**

### **General Description**

The unit has been designed for the short-term holding of pre-prepared merchandise (i.e. Nachos, Pretzels, Popcorn or Non-protein-based foods) product, at a controlled temperature.

### **Assembly Instructions**

1. Remove all packaging material from the Glass Merchandiser unit.
2. Peel off all protective plastic covering from metal.
3. Wash all removable parts in warm, soapy water and dry them thoroughly.

### **Installation**

Check that the power rocker switch located on the front control panel is set to the OFF (O) position.

Position the Vizu Glass Merchandiser unit in the desired position and ensure all four corners of the unit are making contact with surface and the unit is stable and secure. Adjust feet where required.

Connect the unit to mains power supply.

## Control Instructions

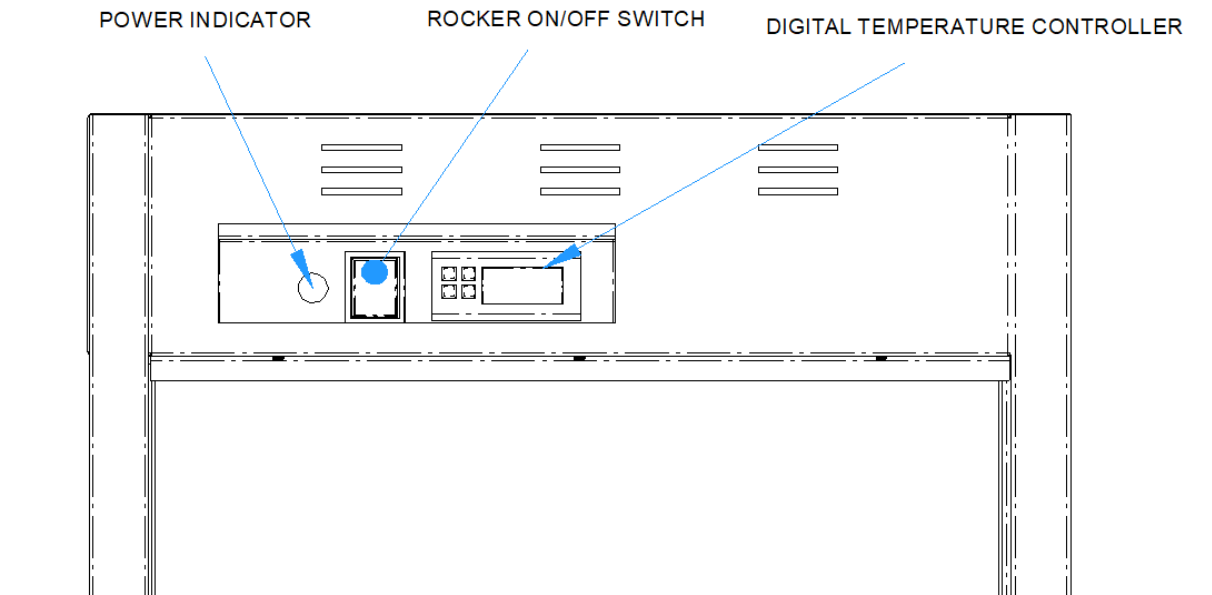

## Operation Instructions

1. Plug into suitable mains power socket and switch 'ON' at wall socket.
2. Red LED power indicator indicates machine is connected to the power supply. When the light is illuminated, this means that the unit is connected to the mains power supply.
3. Green rocker switch allows power to pass to heating elements and internal light units. Position the green rocker switch to " I " to power up lights and heating elements.

## Temperature Control

The digital temperature has been pre-set during manufacturing according to the customers requirements. The digital temperature controller has operating range 30°C - 70°C.

### **To vary factory set temperatures:**

1. Set front green rocker switch to the "O" off position. Ensure that the Mains power indicator is also off. Remove power plug from mains power supply.
2. Remove side panel (when facing front of unit, this is the panel on the left). Once removed an access aperture through which the thermostat dial will be visible, can be accessed.
3. Adjust the dial to the required setting and replace side panel. Follow installation instructions to resume operation at new temperature setting.

### **Cleaning instructions**





1. SWITCH 'OFF' and remove mains electrical cord from wall supply. Allow unit to cool.
2. Remove shelves. Wash shelves in hot soapy water, rinse and dry thoroughly.
3. Wipe all external surfaces with proprietary stainless steel cleaner or warm damp cloth – dry thoroughly.
4. Allow all internal surfaces and unit components to dry thoroughly. Replace shelves.

**DO NOT USE ANY ABRASIVE MATERIALS, SCOURING PADS AND DO NOT USE BLEACH.**

## Spare Parts Listing

PART NO.	DESCRIPTION	QTY.	IMAGE
MFRICA750W	INCOLOY HEATING ELEMENT (750W)	1	
MFMTR11TIRES	DIGITAL TEMPERATURE CONTROLLER	1	
MFNE30	RED LIGHT(POWER INDICATOR)	1	
MFA50-100FB2	50MM DIAMETER STAINLESS STEEL LEG 100MM LONG 63MM FLANGE	4	
BESCHUKO	H05Rr-F 2Mtr. Rubber C032	1	
MFC48-218	POLYCARBONATE DOOR	2	
MFC48-210	GLASS	3	
MFEUROCONVERT	Euro to UK converterplug In black 19-1032	1	
MFCOMMON1	Label 5 140mm x 53mm	1	
MF605-649	Grommet	2	
MFLA100	Oven Lamp Assembly 25W	2	

MF354Z	2 Pole 5amp term block TB06	4	
--------	-----------------------------	---	---

PART NO.	DESCRIPTION	QTY.	IMAGE
VISW17	RED neon rocker Vizu Burger/Passthru	1	
VILE14	Switch cover / bezel HD2/HD4 MFF1025 / MF1026	1	
MF817-8877	Black Nylon 66, strain relief cable bush	1	
FFSLOANPRISMKIT	SLOAN LED PRISM KIT	1	

**Exploded Diagram**

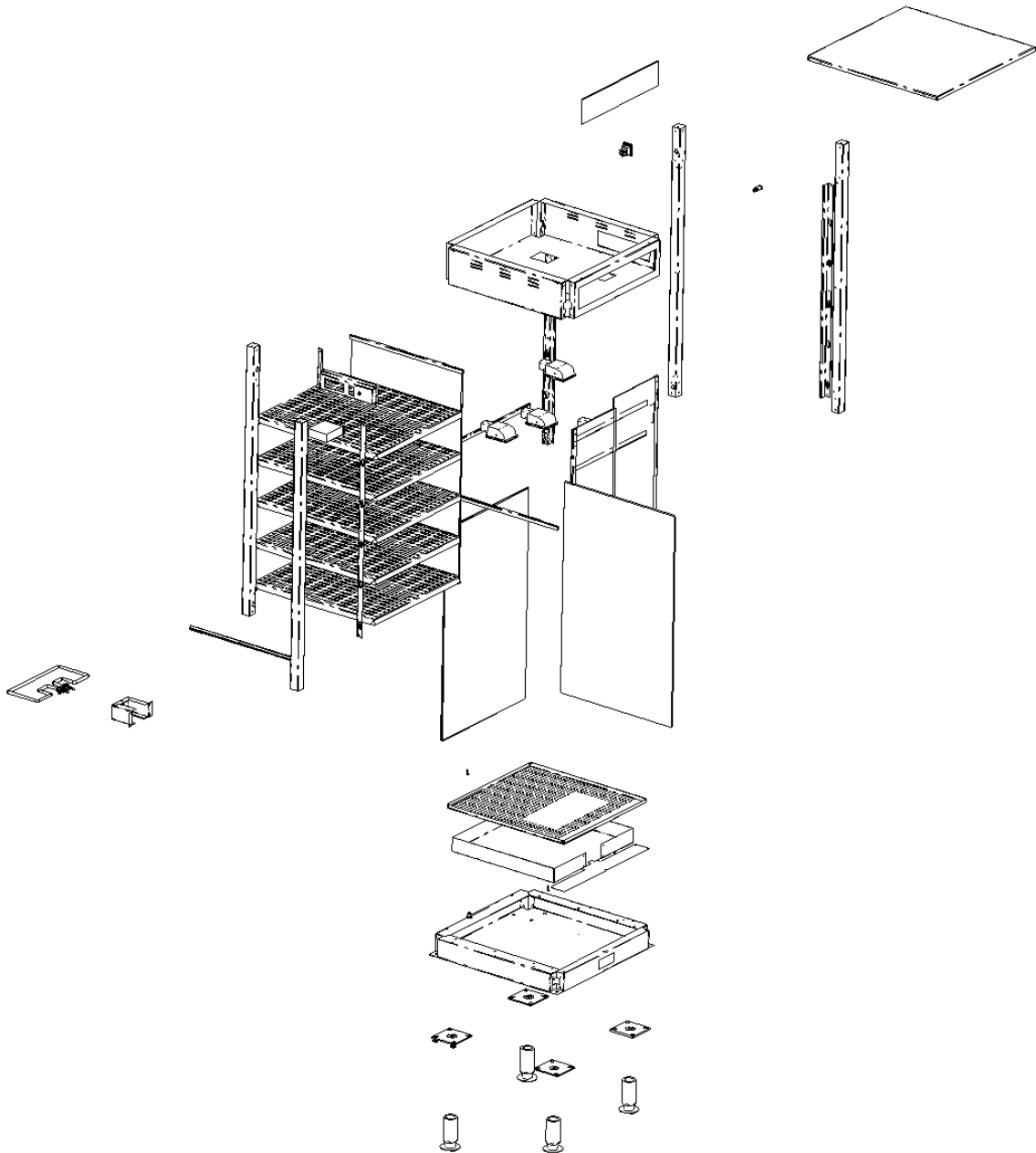



**Exploded Diagram Parts List**

Item Number	File Name (no extension)	Quantity
1	314-204 TOP_	1
2	314-210 Glass Side_	3
3	314-209 FRONT RACK HOLDER_	1
4	314-209 FRONT RACK HOLDER OPP_	1
5	314-208 Top Side Glass channel_	3
6	314-207 Side Glass channel_	3
7	314-206 RACK HOLDER OPP_	1
8	314-202 BEAM PROFILE_	4
9	314-206 RACK HOLDER_	1
10	314-215 SHELF_	5
11	MFELEMNTRICA 750W 230V PIPE	1
12	C48-222 TOP COVER_A	1
13	314-201 BASE_v0.01	1
14	314-205 HEAT REFLECTOR_A	1
15	314-07 WIDE ELEMENT HOLDER_	1
16	314-210 CONTROL PANEL	1
17	DIE PAT FEET PLATE	4
18	DIE PAT HEAVY DUTY FLANGED FOOT 63.5mm	4
19	M4 x 16mm	4
20	M8 11mm HOLE NUTSERT PULLED TO 1.5mm GAP	4
21	314-213 FRONT LED HOUSING	1
22	314A02 DOOR ASSEMBLY	2
23	HUMIDITY CONTROLLER WH8040 AC 220V	1
24	VISW17 + VILE14 - ROCKER SWTICH RED ASSY	1
25	MF NE30 LIGHT RED	1
26	MF LAE37 OVEN LAMP 25W ASSEMBLY	4
27	314-214 POLYCARBONATE SIGN	1
28	314-221 BASE COVER_A	1
29	314-211 CRUMB TRAY_	1



**LIGHTING WIRING DIAGRAM**

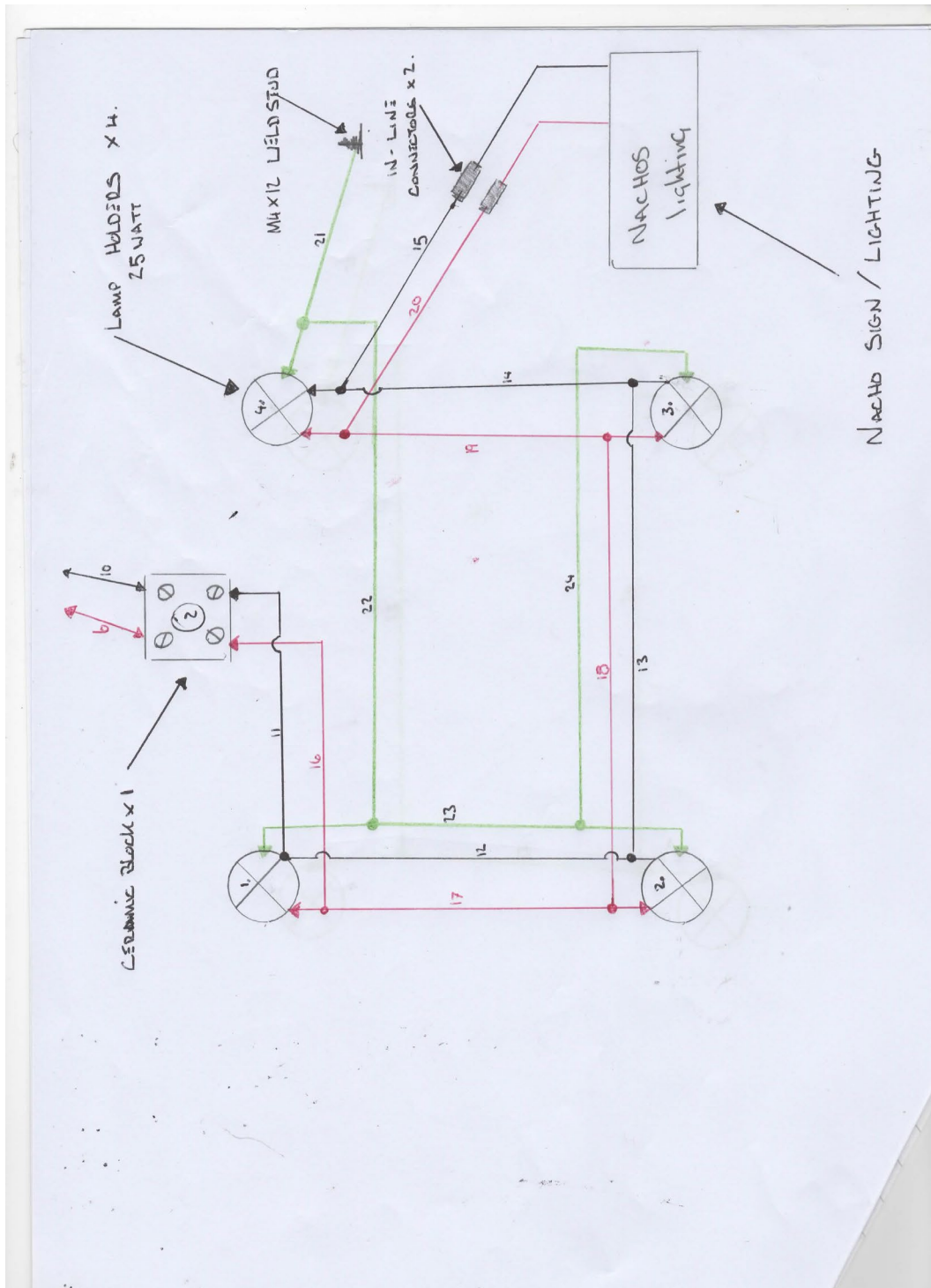

## Fault Finding

Any servicing must only be carried out by qualified professional. Machine must be removed from electrical supply before any servicing.

Any unauthorised servicing and/or repair of this machine may invalidate the warranty.

<b>PROBLEM</b>	<b>POSSIBLE CAUSE</b>	<b>SOLUTION</b>
1. Red LED Power indicator is not illuminated.	<ul style="list-style-type: none"> <li>⇒ Wall socket switched OFF.</li> <li>⇒ Fuse in plug faulty.</li> <li>⇒ Power supply failed.</li> </ul>	<ul style="list-style-type: none"> <li>• Switch ON.</li> <li>• Replace fuse.</li> <li>• Check power supply</li> </ul>
2. Red Rocker switch is not illuminated.	<ul style="list-style-type: none"> <li>⇒ Red rocker is in OFF (O) position.</li> <li>⇒ Red rocker switch faulty.</li> </ul>	<ul style="list-style-type: none"> <li>• Switch ON.</li> <li>• Replace switch.</li> </ul>
3. Machine does not heat up	<ul style="list-style-type: none"> <li>⇒ No supply to Digital Temp Controller</li> <li>⇒ Digital Temp Controller is faulty</li> <li>⇒ Loose/broken wiring or connection heat element faulty.</li> <li>⇒ Machine has overheated</li> </ul>	<ul style="list-style-type: none"> <li>• See section 1 and 2.</li> <li>• Replace the Digital Temp Controller</li> <li>• Identify fault and correct</li> <li>• Find and correct</li> <li>• Replace element</li> <li>• Allow to cool down</li> </ul>
4. Light are not illuminated when unit is on.	<ul style="list-style-type: none"> <li>⇒ Faulty bulbs</li> <li>⇒ Connection fault</li> </ul>	<ul style="list-style-type: none"> <li>• Test and replace bulbs is required</li> <li>• Check connections</li> </ul>

# Terms and Conditions

## Claims

No claim shall be entertained by the Company unless made in writing. Claims arising from damage or partial loss in transit must reach the Company within 7 days from the date of delivery. Claims for non-delivery must reach the Company within 10 days from the date of dispatch. All other claims must reach the Company within 7 days. Damaged goods must be retained for inspection/collection.

## Returns

The Company does not operate a returns policy unless the goods are defective:

In circumstances where the Company agrees to accept return of goods, a charge of 25% of the invoice value will be made.

**Damage claim form**

Machine: **VIZU® GLASS MERCHANDISER**  
Product code: **VIGM-T**

Customer name.....

Date of delivery.....

Machine serial number.....

Damage comments.....

.....  
.....  
.....  
.....

Please indicate on the pictures where the unit is damaged

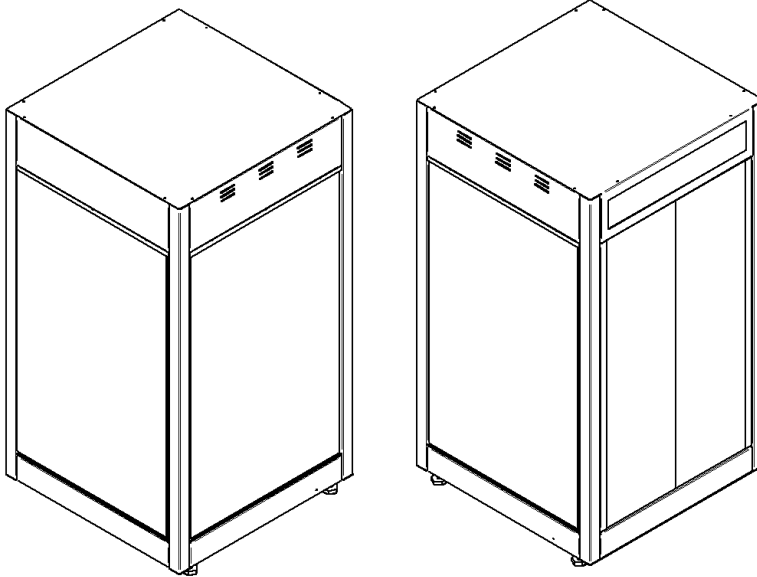

Courier name.....



Please cut this page out and post to **Fast Food Systems**  
(The address is on the back of this manual)

# Warranty

## UNITED KINGDOM AND REPUBLIC OF IRELAND

Excepting where otherwise specified all products are subject to 12 months parts and labour warranty. Goods found defective will be repaired, credited or replaced without charge according to the terms of the Company's standard warranty, provided written notice is given within the guarantee period. In no case will the company be liable for repairs made without it's knowledge or sanction, or for indirect damage, or any consequential loss or expense incurred by purchasers.

Fast Food Systems Ltd, warrants to the original purchaser that the equipment supplied to be free from defective materials or workmanship for a period of 12 (twelve) months.

The following are NOT covered by warranty:

1. Failure or breakdown caused by incorrect installation.
2. Adjustment or calibration of controls - this is a routine maintenance function.
3. Abuse or misuse, including cleaning.
4. Warranty labour is only carried out during normal working hours, calls out of hours may be subject to surcharges.
5. The warranty will commence either on installation or 1 (one) month from date of dispatch - whichever is the sooner.
7. Warranty on spare parts purchased for equipment outside of the warranty period is 3 (three) months from date of sale.
8. Any faulty spare parts replaced under warranty must be returned with 7 days of supply.
9. Warranty is non-transferable.

**Fast-Food-Systems Ltd** will not be held responsible, financially or otherwise, for any loss of business as a result of equipment breakdown.

**NOTES:**



Model Number: VIGM-T

Order ID/Job No.....

Machine serial number.....

Date of Manufacture ...../...../.....

Date of delivery...../...../.....

Date of commissioning...../...../.....

	<p><b>ENGLISH</b></p> <p>Electrical equipment marked with this symbol may not be disposed of in European public disposal systems after 12 August 2005. In conformity with European local and national regulations (EU Directive 2002/96/EC), European electrical equipment users must now return old or end-of-life equipment to the manufacturer for disposal at no charge to the user.</p> <p><b>Note:</b> For return for recycling, please contact the equipment manufacturer or supplier for instructions on how to return end-of-life equipment for proper disposal.</p>
---	---

**Fast Food Systems Limited**  
 Manufacturer & Distributor of Catering Equipment

Unit 1 Headley Park 9 Headley Road East

Woodley Reading Berkshire RG5 4SQ

Tel: 0118 944 1100 Fax: 0118 944 0350

Email: [service@fast-food-systems.co.uk](mailto:service@fast-food-systems.co.uk)

Website: [www.fast-food-systems.com](http://www.fast-food-systems.com)

ISSUE 3: 25<sup>th</sup> June 2024