

# 3 Tier Food Chute

*VI3TFC*



- Stainless steel construction
- Heat lamp heat from above
- Adjustable lane guides to different widths
- Lane Labels available for quick reference both loader and server
- Only top heat for all three tiers
- Easy to clean removable parts

### 3 Tier Food Chute Specification Page

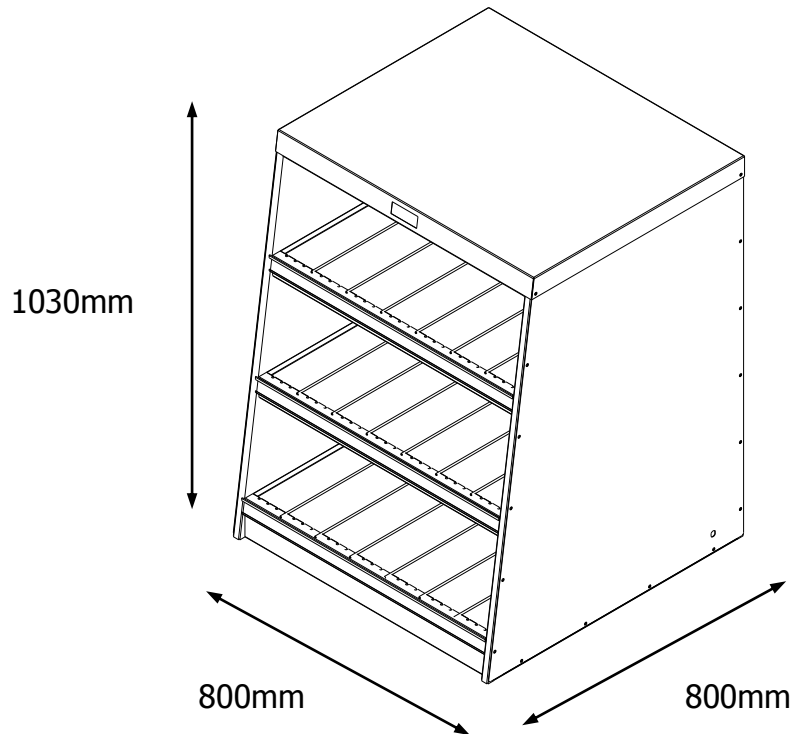

#### **Model VI003G**

<p><b>Dimensions</b>                  Height                  Width                  Depth</p>	<p><b>Machine</b>                  1030mm                  800mm                  800mm</p>
<p><b>Weight</b></p>	
<p><b>Electrical</b>                  Running Amps                  Connection Type                  International Option</p>	<p><b>1 phase, 50HZ AC, 230v, 2.4Kw</b>                  10.4 Amps                  BSCHUKO 2 Pin With 3 Pin UK Adaptor                  N/A</p>

All **Vizu 3 Tier Food Chutes** have been tested and checked for proper operation before leaving the factory.

Upon delivery please check the unit for damage. If the unit is damaged, contact the carrier, or fast food systems, immediately and file a damage claim (found in the back of the manual) Please retain all packing materials.

**Damage must be reported within 7 days of delivery**

## **General Description**

The unit has been designed to hold burgers and other cooked, wrapped or boxed foods ready for service.

## **Assembly Instructions**

Remove all packing from the unit.

Peel off all protective plastic covering from metal

Wash all removable parts in warm, soapy water and dry them thoroughly.

Place trays in position.

## **Installation**

Position the *Vizu 3 Tier Food Chute* in desired position, close to a suitable electrical supply and connect.

## **Operating Instructions**

Switch the red rocker switch to the 'ON' position.

The top, middle and bottom sections are controlled independently using the green rocker switches.

Allow unit to heat up for 20 minutes.

## **Cleaning Instructions**

Disconnect the unit from its power supply.

Remove trays and clean.

Clean all stainless steel surfaces with proprietary stainless steel cleaner, such as Sheila Shine and a soft lint free cloth.

**Note: Do NOT use abrasive cleaners or pads and do NOT bleach.**

Wipe ceramic elements only when they are cold with a damp clean cloth.

Do NOT touch or clean (quartz) heat lamps with fingers, as this will reduce the life of the tubes.

Dry all surfaces thoroughly removing all moisture.

Replace trays and re-connect to power supply.

### 3 Tier Food Chute Exploded Diagram

Item Number	File Name (no extension)	Quantity
1	85-02 INNER SIDE MIRROR	1
2	85 EDV3TFC TOP SHELF ASSEMBLY WITH LAMPS	1
3	85 EDV3TFC UPPER MIDDLE SHELF ASSEMBLY WITH LAMPS	1
4	85 EDV3TFC LOWER MIDDLE SHELF ASSEMBLY WITH LAMPS	1
5	85-05 LOWER MIDDLE SHELF	1
6	85-03 UPPER SHELF	1
7	85-02 INNER SIDE	1
8	85-01TOP	1
9	85-11BASE	1
10	85 EDV3TFC UPPER MIDDLE CHUTE ASSEMBLY	1
11	85 EDV3TFC LOWER MIDDLE CHUTE ASSEMBLY	1
12	85-04 BASE SHELF	1
13	85 EDV3TFC BASE CHUTE ASSEMBLY	1
14	85-13 SIDE COVER MIRROR	1
15	85-13 SIDE COVER	1
16	ON & OFF SWITCH	1
17	VISW17 SWITCH (GREEN)	3
18	85-06 STIFFENING GUSSET	4
19*	SERIAL NO PLATE	1
20*	85 - 95 MAIN PANEL WRAPSTAND	1
21*	85 - 95 BACK PANEL WRAPSTAND	1
22*	66-03 POLE BRACKET	2
23*	85 - 96 DIVIDER ROD	1
24*	66-08 DIVIDER	3
25*	244 - DOOR TEST	1

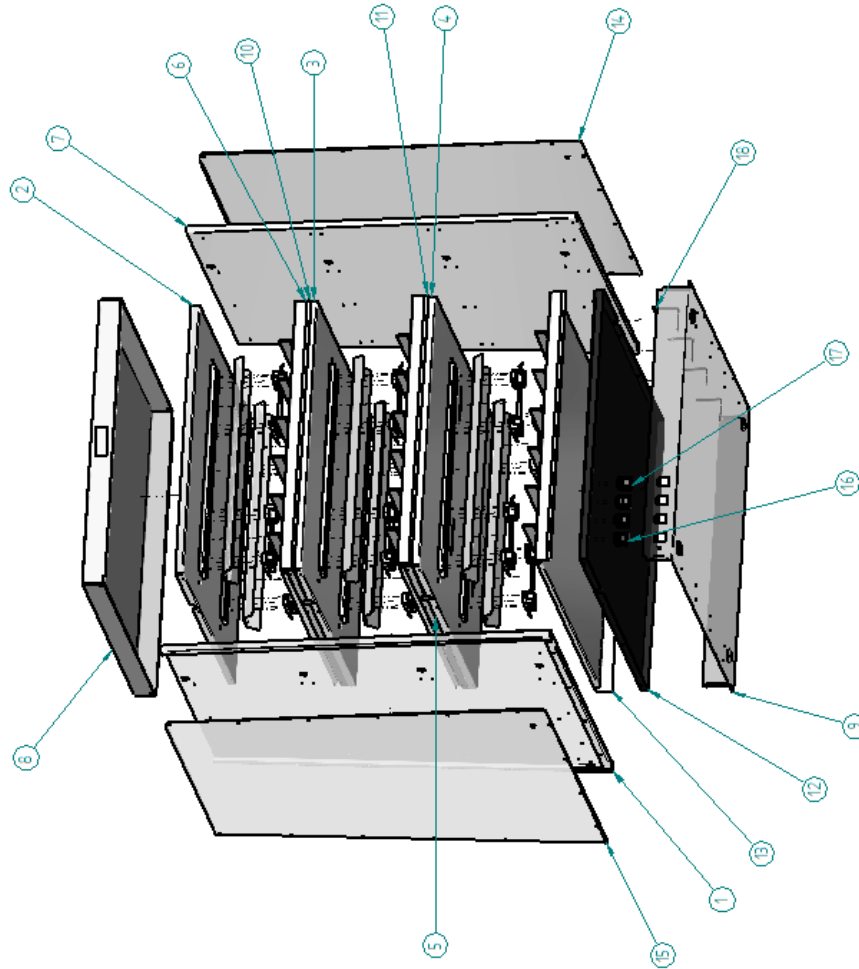

## Faultfinder



Any servicing must be carried out by qualified personnel.

Disconnect from power before servicing.

<b>Problem</b>	<b>Possible cause</b>	<b>Solution</b>
Indicated ON/OFF (RED switch) does not illuminate.	1a No power to machine.	1aa Check machine is plugged in and switched on.  Check fuse in plug.  Check circuit breaker at mains supply board is in i.e. ON.  Replace switches.
One or all the green switches do not illuminate.	2a Switch (es) in OFF position.  2b Switch faulty.	2aa See Section 1.  2bb Switch on.  Replace switch.
All green switches are illuminated, but one or more halogens are not.	3a Halogen incorrectly fitted.  3b Faulty halogen lamp.  3c Switch faulty.  3d Halogen holder faulty.  3e Loose or faulty wiring.	3aa Fit correctly.  3bb Replace halogen.  3cc Replace switch.  3dd Call maintenance  3ee Call maintenance.

## Spare Parts Listing

PART NO.	DESCRIPTION	QTY.	IMAGE
BESCHUKO	H05Rr-F 2Mtr. Rubber C032	1	
MF374-1029	100mm low profile lens indicator 230VAC	1	
EQVIZULABELS	MQ4658CR VIZU LABELS (10 PER SET)	3	
MF3001200	Strain relief bush	1	
MF354Z	2 Pole 5amp term block TB06	9	
MFOHSL01	High temperature sleeving	3	
MF605-649	Grommet	4	
MFCOMMON1	Label 5 140mm x 53mm	1	
MFEUROCONVERT	Euro to UK converterplug In black 19-1032	1	
VILE14	Switch cover / bezel HD2/HD4 MFF1025 / MF1026	4	
VISW15	Green neon rocker Vizu Burger/Passthru	3	
VISW17	Rocker switch HD2 Revolva HD4 MFC1553ALR	1	

PART NO.	DESCRIPTION	QTY.	IMAGE
MFQUARTZJACKET 200W	Jacket assembly 200W	12	
MF200WRJ	IRL 200JV 200W Jacketed IR Quartz Bulb	12	

**Warning, when replacing bulbs**

The lamps whilst being a high output unit are fragile. They must be handled with care and they must be kept clean. Guards are fitted to prevent dirt and grease contacting the bulbs. Grease from fingers will weaken the surface of the bulb this will lead to fracture and failure; bulbs should always be held using gloves or a wad of tissue to grip the bulb in.



**Wiring Diagram**

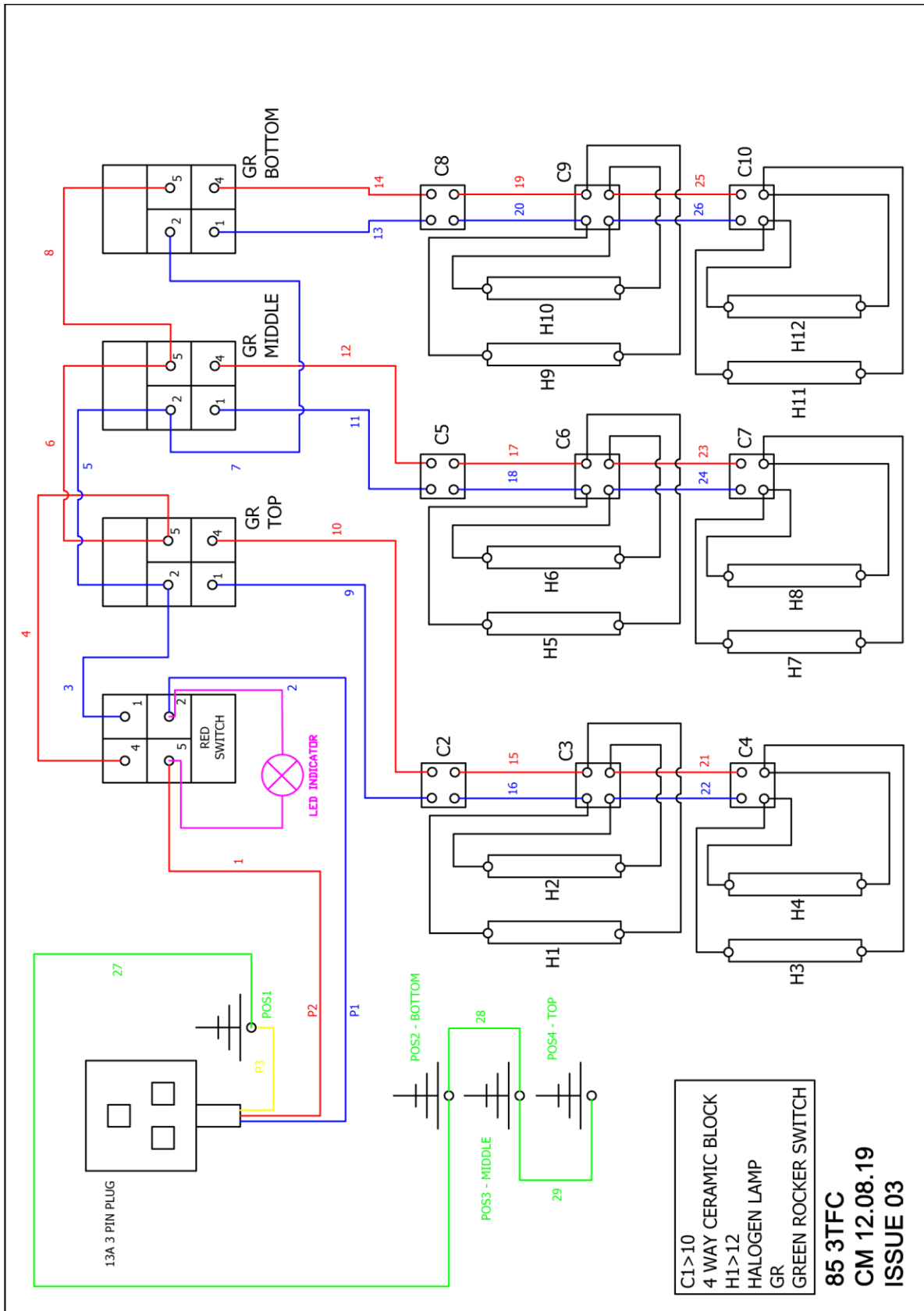

## Damage claim form

Machine: **3 Tier Food Chute**

Product code: **VI3TFC**

Customer name.....

Date of delivery.....

Machine serial number.....

Damage  
comments.....  
.....  
.....  
.....  
.....

Please indicate on the picture where the unit is damaged

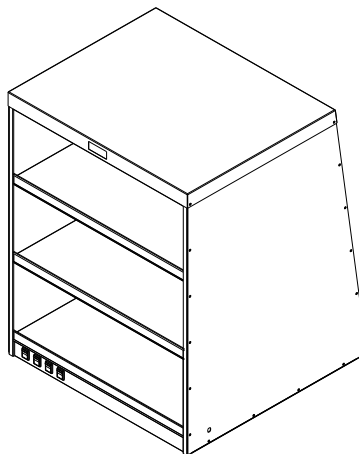
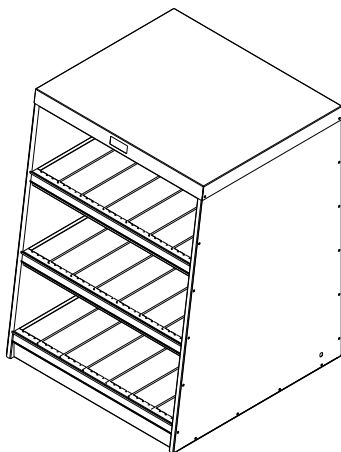

Courier name.....

Please cut this page out and post to **Fast Food Systems**  
(The address is on the back of this manual)



# Terms and Conditions

## **Claims**

No claim shall be entertained by the Company unless made in writing. Claims arising from damage or partial loss in transit must reach the Company within 7 days from the date of delivery. Claims for non-delivery must reach the Company within 10 days from the date of dispatch. All other claims must reach the Company within 7 days. Damaged goods must be retained for inspection/collection.

## **Returns**

The Company does not operate a returns policy unless the goods are defective:

In circumstances where the Company agrees to accept return of goods, a charge of 25% of the invoice value will be made.

## Warranty

### *UNITED KINGDOM AND REPUBLIC OF IRELAND*

Excepting where otherwise specified all products are subject to 12 months parts and labour warranty. Goods found defective will be repaired, credited or replaced without charge according to the terms of the Company's standard warranty, provided written notice is given within the guarantee period. In no case will the company be liable for repairs made without its knowledge or sanction, or for indirect damage, or any consequential loss or expense incurred by purchasers.

Fast Food Systems Ltd, warrants to the original purchaser that the equipment supplied to be free from defective materials or workmanship for a period of 12 (twelve) months.

The following are NOT covered by warranty:

1. Failure or breakdown caused by incorrect installation.
2. Glass parts, electric lamps or door seals.
3. Adjustment or calibration of controls - this is a routine maintenance function.
4. Abuse or misuse, including cleaning.
5. Warranty labour is only carried out during normal working hours, calls attended to out of hours may be subject to surcharges.
6. The warranty will commence either on installation or 1 (one) month from date of dispatch - whichever is the sooner.
7. Warranty on spare parts purchased for equipment outside of the warranty period is 3 (three) months from date of sale.
8. Any faulty spare parts replaced under warranty must be returned with 7 days of supply.
9. Warranty is non-transferable.

***Fast-Food-Systems Ltd*** will not be held responsible, financially or otherwise, for any loss of business as a result of equipment breakdown.

NOTE...

NOTE...

NOTE...

Model Number.....

Order ID/Job No.....

Machine serial number.....

Date of Manufacture ...../...../.....

Date of delivery...../...../.....

Date of commissioning...../...../.....



**ENGLISH**

Electrical equipment marked with this symbol may not be disposed of in European public disposal systems after 12 August 2005. In conformity with European local and national regulations (EU Directive 2002/96/EC), European electrical equipment users must now return old or end-of-life equipment to the manufacturer for disposal at no charge to the user.

**Note:** For return for recycling, please contact the equipment manufacturer or supplier for instructions on how to return end-of-life equipment for proper disposal.

**Fast Food Systems Limited**

Manufacturer & Distributor of Catering Equipment

Unit 1 Headley Park 9 Headley Road East

Woodley Reading Berkshire RG5 4SQ

Tel: 0118 944 1100 Fax: 0118 944 0350

Email: [service@fast-food-systems.co.uk](mailto:service@fast-food-systems.co.uk)

Website: [www.fast-food-systems.com](http://www.fast-food-systems.com)

ISSUE 10: 14.06.17